

Non-Linear Time-Cost Break Even Research in Product Lifecycle

Rūta Lapašinskaitė, Vytautas Boguslauskas

Kauno technologijos universitetas
K. Donelaičio g. 73, LT-44029, Kaunas

This article describes the life cycle concept that can be used to evaluate the true cost of the product. It can help managers to understand acquisition costs versus operating and support costs. Life Cycle Costing (LCC) method can be used to evaluate alternatives being considered for either to buy a new product or repair the old product.

The first step in determining the life cycle cost is to quantify the costs associated with all the alternatives. These costs should be identified as installed cost (material and labor), energy cost per year, maintenance cost per year. The second step is to forecast operating and maintenance expenses over time. The third step is to determine the present value of future operating and maintaining costs. To take into account the cost of capital, future operating and maintenance costs must be translated into their present value.

There are at least three options open to a customer: it is possible to do a major overhaul, to buy a new unit, or to do nothing. Each possibility represents a kind of investment alternative, and each must therefore be well defined and assessed to show the cost impact of the decision over the item's lifespan. The resulting analysis will furnish management with the answers needed to support a decision and to home in on the most advantageous timing.

The first alternative is doing nothing. Then the customer needs to try to assess the wear and tear it will undergo in the future, look for cost factors that might have been previously overlooked. Usually this is the least attractive choice for maintenance staff and equipment operators, who would much, rather scrap the unit and buy new.

The second alternative is to buy a new product. In this case there are a few typical considerations described in the article. Between "doing nothing" and "buying new," there may be other options worth looking at taking a comparatively "minimalist" approach to maintenance as opposed to an "optimal" maintenance strategy.

Maintenance costs are dominating life-cycle costs because maintenance tends to be done over a period of time, usually many years.

Using exponential regression method it was calculated the time-cost break even where accumulated operational and maintenance costs reached the level in that it is better to buy a new one product having the same recourses in order to use the old product. Nonlinear time-cost break even shows the life cycle period where accumulated costs are equal new product's acquisition costs.

The time-cost break even was found with the help of business program VisSim 5.0. Once these model's calcu-

lations have been completed, the final decision is simple: choose the lowest life cycle cost. The least-cost approach can be used to evaluate a wide variety of projects and financial mechanisms. In all cases the calculation of life cycle costs will yield the most accurate indication of the products financial performance.

Keywords: *life cycle costing, product life cycle, time-cost break even.*

Introduction

Life cycle analysis is widely used in many applications, although it has also been thoroughly criticized. Life cycle costing has had considerable theoretical development, but few practical applications (Adamany & Gonsalves, 1994).

Most of the criticism against the life cycle concept concerns its use in marketing. "Forget the product life cycle!" (Dhalla and Yuspeh, 1976). The opponents criticize mainly the use of the bell-shaped sales curve as a default or self-evident behavior of product sales. They demonstrate their point by illustrating the poor fitting of the curves using some empirical examples of product class, product form or brand. On the other hand, Barksdale and Harris (1982) have later presented evidence showing that the bell-shaped curve is a reasonable model of the sales record for many types of product (Gardner, 1987).

The benefits of life cycle concepts are summarized as follows:

- The life cycle concept results in earlier actions to generate revenue or to lower costs than otherwise might be considered.
- Better decisions should follow from a more accurate and realistic assessment of revenues and costs, at least within a particular life cycle stage.
- Life cycle thinking can promote long-term rewarding in contrast to short-term profitability rewarding.
- The life cycle concept helps managers to understand acquisition costs versus operating and support costs, i.e. to find a correct balance between investment costs versus operating expenses. (Sushman, 1989)

Many articles also deal with the complexity of modeling the product sales behavior and using the model to predict the phases of product life (Lambkin and Day, 1989).

There are some quite commonly agreed features (Gardner 1987):

1. Products have a limited life.
2. Their sales history follows a S-shaped curve until the annual sales level off, when penetration of the potential market has been achieved, and eventually decline.
3. The inflection points in the sales history identify the stages known as introduction, growth, maturity, and decline. Some life cycles add more stages, including a period of shakeout or competitive turbulence once growth has begun to slow down.
4. Finding new uses or new users or getting the present users to increase their consumption may extend the life of the product.
5. The average profitability per unit rises and then falls as products move sequentially and inevitably through the stages.

When evaluating the cost of products it is very important to forecast operating expenses over the life cycle of the product because operating expenses can be 10 times greater than acquisition costs. For this reason it is prudent to consider all the time when it is better to finish usage of the product.

The true cost of the product can be evaluated using life cycle cost (LCC) method. This method takes all costs into account – including the acquisition costs, the cost of capital and the operating and maintenance expenses that are occurred over the life cycle of the product.

LCC method can be used to evaluate alternatives being considered for either new product or repair of the old product. In either case, simply to choose the alternative with the least life cycle cost – the lowest overall costs.

Repair – or replace? When it comes to long term asset, it's the eternal question. It is also a business decision that ought to be made on the basis of relative costs and tradeoffs. Before you go to management with a repair or-replace recommendation, you should be able to explain how the alternatives will affect your operation's bottom line.

The purpose of this article is to find the break even where the maintenance and operational costs over the time period are equal to product's acquisition costs.

The object is acquisition, operational and maintenance costs in the product's life cycle.

Evaluation the Life Cycle Costs

Step one: Count the Costs

The first step in determining the life cycle cost is to quantify the costs associated with all the alternatives. These costs should be identified as follows (Wood, 2002):

- Installed cost (material and labor).
- Energy cost per year.
- Maintenance cost per year.

Step two: forecast operating and maintenance expenses over time.

We need to forecast the cost of operating and maintaining the product over the life cycle. But how long is the life cycle? In most cases there are two ways:

1. Keep the product in use for at least n years, what is meant useful time.

2. Move out the product after it useful time.

Well-established businesses should assume n years for the analysis; businesses that have uncertain future plans should use a shorter term. However the underestimating the life cycle term can yield decisions that do not maximize profit or minimize cost.

When projecting operating and maintenance costs over time, it is important to include an estimate of inflation to reflect expected long-term price increases in material, labor and energy. Within this information, it will be possible to calculate the total cost of purchasing, operating and maintaining the product over the life cycle.

Step three: determine the present value of future operating and maintaining costs.

To take into account the cost of capital, future operating and maintenance costs must be translated into their present value. In the same way that interest rates translate a present value (today's investment) into future value (principal plus interest), discount rates translate future costs into present value costs (Wood, 2002).

The present value calculation is simply the interest rate calculation working in reverse.

Why translate the future costs into the present value? By expressing all future costs in their present value, we can express the total life cycle cost of a product as a single Litas amount, payable today.

Typically, the value should be related to the financial returns that the organization expects to yields on low risk capital investments. Most organizations have a specific discount rate that is used for evaluating capital investments.

Using a standard "net present value" (NPV) spreadsheet function, each future cost can be discounted to the present value using the following formula:

$$\text{Present value} = \text{Future cost} \times (1 / (1 + \text{Discount Rate})^n) \quad (1);$$

Where

Discount Rate is expressed as an annual decimal value;

n is the number of years from today that the future cost occurs in the cash flow.

End of life disposition

You have taken a hard look at your product, and what you see tells you that some units just aren't cutting it. Something needs to be done – but what? There are at least three options open to customer (Hawkins, 2002):

- You can do a major overhaul,
- You can buy a new unit, or
- You can do nothing.

Each possibility represents a kind of investment alternative, and each must therefore be well defined and assessed to show the cost impact of the decision over the item's lifespan. The resulting analyses will furnish management the answers needed to support a decision and to home in on the most advantageous timing. How does Maintenance go about it? Here's an overview of the life-cycle costing process for maintenance and purchasing as outlined by engineering consultant Paul Barringer, P.E. For illustration purposes, it was taken the case of an ag-

ing forklift truck that's prone to breakdowns and soaks up lots of time, attention, and money for parts. Is it better to repair or buy a new truck?

Scenario One: Doing nothing

The first alternative that we must always consider, says Barringer, is doing nothing. We need to know the cost of continuing our present activity – i.e., buying no upgrades and simply patching and repairing as needed. This is our baseline. If we have kept good cost and repair records, it is easy to do the analysis by creating a spreadsheet that projects the future out-of-pocket expenditures. Include on the sheet both routine scheduled costs and exceptional ones, such as new tires, batteries, starter motors, hydraulic pumps, and hoses. “With older trucks,” Barringer notes, “you may have considerable monthly maintenance needs.” But in any case, for a proper life-cycle costing we must develop a full understanding of all events associated with the equipment. “If you don't know how things ‘live’ and ‘die,’” he notes, “you will never be able to do an effective job of pricing them out.” (Hawkins, 2002) So, we have to dig into the files for the truck's repair history and future reliability prospects. We have to try to assess the wear and tear it will undergo in the future. We have to look for cost factors that might have been previously overlooked. Here are few examples:

- Factor in a cost for random future failures as well as predictable ones based on “known” wear-out and deterioration rates.
- Include a measurement for the loss of productivity that occurs whenever the nonworking forklift truck is removed from service.
- Consider electricity and fuel costs. Energy usage may vary significantly between older machines and later, high-efficiency models.
- With older equipment we need to perform extraordinary safety inspections.

Other similar spreadsheet categories may also be added according to the differing maintenance assumptions that you make and the specific equipment in question. The result of the tabulations is the profile for “doing nothing.” Usually this is the least attractive choice for maintenance staff and equipment operators, who would much, rather scrap the unit and buy new. “Doing nothing” is usually the least costly alternative and thus the most appealing to financial people eyeing the bottom line. Even if “buying new” is desired goal, you should prepare this “doing nothing” case as a point of reference.

If we want to cost justify the new truck, we must factor in every nickel- and-dime repair and maintenance expense we can identify under the “do nothing” alternative.

Scenario Two: Buying New

Next costing of a second option is the purchase of a new forklift. In the case of buying new, here are a few typical considerations (Hawkins, 2002) :

- Additional costs are often associated with a new equipment break-in period. These include such things as operator and technician retraining.
- Failure of new components is an often-overlooked reality and cost factor, especially with new systems comprised of hundreds or thousands of new parts or subsystems.

- Brand new machinery and equipment often require different standards of “care and feeding,” such as warranty-related maintenance or specific kinds of shakedown or commissioning inspections and procedures.
- Presumably you can expect fewer unscheduled repairs.
- Predictive and preventive maintenance schedules will almost certainly be adjusted.
- You may also find other no maintenance related costs to factor in, such as adjustments in insurance premiums.

In addition to these new-equipment life-cycle costs, it is possible explore other “what if?” spreadsheet scenarios representing a range of choices. These might include buying the lowest cost versus a midrange and a top-of-the-line model, or a quality used one. It is also possible to weight the purchase decision in relation to projected needs and demands. Buying a cheaper model may show up negatively in lost productivity over the long run, as well as in higher repair costs and in shorter equipment life. “It's unwise to pay too much,” Barringer observes, “and it's foolish to pay too little.” (Hawkins, 2002)

Finally, besides evaluating basic parameters such as load capacity, it often pays to explore other dimensions, such as speed and projected lifespan. On this point, however, Barringer advises, “Be skeptical of manufacturers' claims,” as these sometimes do not reflect real-world conditions. (Hawkins, 2002)

Scenario Three: Repairing and Maintaining

Between “doing nothing” and “buying new,” there may be other options worth looking at: taking a comparatively “minimalist” approach to maintenance as opposed to an “optimal” maintenance strategy, for example. “Some approaches will add to equipment life,” Barringer notes, thereby altering the spreadsheet results, while other strategies detract from the equipment's rated life (Hawkins, 2002). A low-level effort, as would be suitable for equipment with a three year anticipated future, will differ markedly from a high-end strategy for hardware intended to remain in service for many years.

Having factored together all of the costs for each option or scenario, one critical step now remains: to run each spreadsheet through a sophisticated financial analysis.

Figures should typically include such concepts as Litas discount factors, the inflationary impact on expense, balance sheet implications of capital equipment, and even some consideration of alternative investment options for the proposed expenditures apart from plant needs, as well as financing costs, amortization, and more.

Incorporating these factors often requires outside expertise, but it is crucial for the credibility. With the intelligent alternatives plotted out fully, we are ready to make the correct maintenance investment, or argue for new equipment. Rigorous life-cycle costing proves itself absolutely necessary in solving the “repair or replace?” riddle (Dunnett, 1992).

Steps of the non-linear time-cost break even model

Because the purchase price the customer pays is equal to the cost of the producer plus value added, the life

cycle costs of the customer perspective will most often be complete.

What is life cycle cost? Some of the better definitions are (Emblemsvag, 1999):

- The sum total of the direct, indirect, recurring, nonrecurring, and other related cost incurred, or estimated to be insured, in the design, development, production, operation, maintenance, and support of a major system over its anticipated useful life span.
- The amortized annual cost of a product, including capital costs, installation costs, operating costs, maintenance costs, and disposal costs discounted over the lifetime of a product.
- The total cost throughout its (an asset's) life, including planning, design, acquisition and support costs, and any other costs, directly attributable to owning or using the asset.

In this article the most attention will be paid on product's operational and maintenance costs.

Maintenance costs dominate life-cycle costs because maintenance tends to be done over a period of time, usually many years (sometimes decades) (Wanyama, 2003).

By making this theoretical model we will have this presumption: product's operational and maintenance costs are growing according to the predictive value (exponential function).

According to this presumption it can be said that in order to use the product it will be needed to spend more and more operational and maintenance costs each year. And costs are increasing according to increased rate.

$$y=c \cdot e^{dx} \quad (2)$$

Where:

- y is operational and maintenance costs;
- x is time;
- c and d are parameters.

This cost increase will be described with the help of the model created by Lapasinskaite (Lapasinskaite, 2005):

$$\text{Operational costs}=595.1206 \cdot e^{0.165358 \cdot \text{time}} \quad (3)$$

Using exponential regression method we can calculate the time-cost break even where accumulated operational and maintenance costs will reach the level in what it is better to buy a new one product having the same resources in order to use the old product. Nonlinear time-cost break even shows the life cycle period where accumulated costs are equal new product's acquisition costs.

The break even will be found with the help of business program VisSim 5.0. The program meaning is to make wished function simulation modeling after variables and connections between them are described.

So if we change in formula (3) acquisition costs instead of the operational and maintenance costs we will have another function:

$$\text{Acquisition cost}=595.1206 \cdot e^{0.165358 \cdot \text{time}} \quad (4)$$

If we model this model with the help of VisSim 5.0. we can get this graphical view.

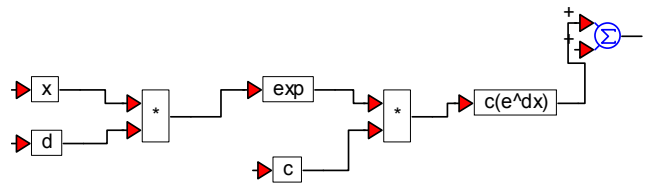

Figure 1. Graphical exponential model's view

Where:

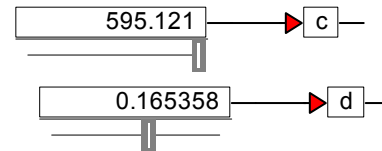

Figure 2. Parameters c and d meanings in the model

We add Time after acquisition generator that helps us to analyze costs in different times in the mathematical model (see Figure 3).



Figure 3. Time after acquisition Generator

Model is held on while accumulated operational and maintenance costs are equal acquisition value.

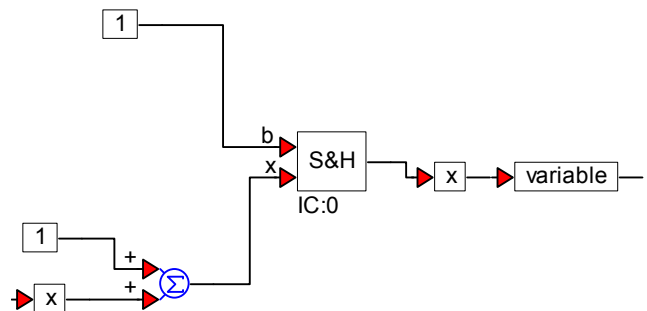

Figure 4. Duration of the Modeling

One important value that should be set in the model is value of the constraint, e.g. product's acquisition value in this case (see Fig. 5)

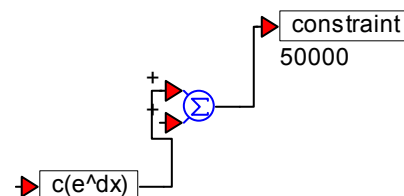

Figure 5. Constraint value influence to model result

In Figure 6 we can see the total view of the model. This model calculates accumulated operational and maintenance cost in each time period and compares it with the acquisition value. Incoming data are described above.

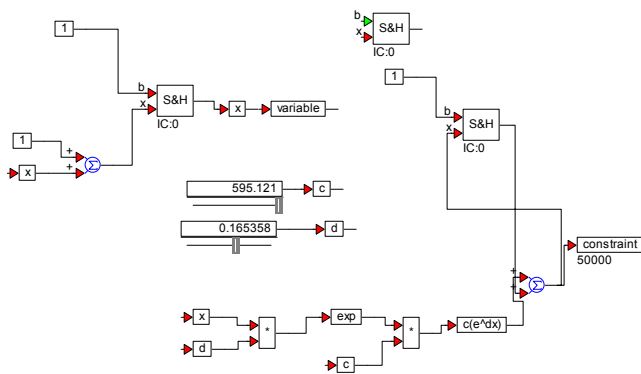

Figure 6. Total nonlinear time-cost break even model

In Figure 7 it can be seen the graphical calculated nonlinear time-cost break even.

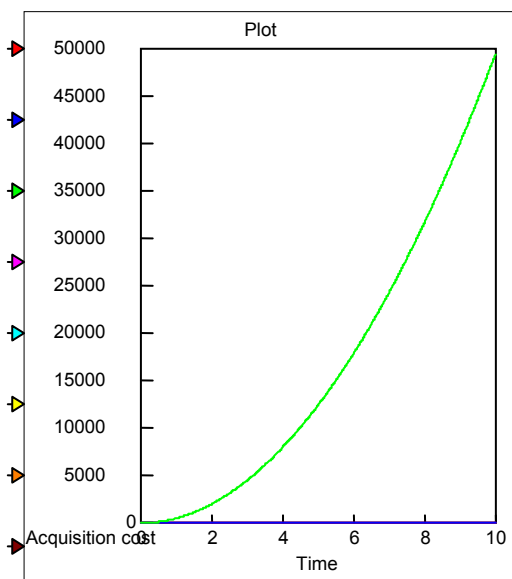

Figure 7. Calculated nonlinear time-cost break even

Once these model's calculations have been completed, the final decision is simple: choose the lowest life cycle cost. The least-cost approach can be used to evaluate a wide variety of projects and financial mechanisms. In all cases the calculation of life cycle costs will yield the most accurate indication of the products financial performance.

Conclusions

The following conclusions may be drawn:

1. There are three main options at the end of product life cycle: to maintain and repair it, to buy a new product or to do nothing.
2. Maintenance costs are dominating life-cycle costs because maintenance tends to be done over a period of time, usually over many years.
3. Non-linear time-cost break even shows the life cycle period where accumulated costs are equal new product's acquisition costs.
4. The least-cost approach can be used to evaluate a wide variety of projects and financial mechanisms. In all cases the calculation of life cycle costs will

yield the most accurate indication of the products financial performance.

References

1. Adamany, G. Life Cycle Management / G.Adamany, F.A.M.Gonsalves. Boston, MA: Warren, Gorham& Lamont, 1997. P. 1 -26.
2. Adamany, G. Life cycle management: An integrated approach to managing investments / G.Adamany, F.A.M.Gonsalves // Cost management, 1994, Vol. 8, No 2, p. 35 -48.
3. Asiedu, Y. Product life cycle cost analysis: state of the art review/ Y.Asiedu, P. Gu// International Journal of Production Research, 1998, Vol.36, p. 883-908.
4. Barksdale, HC. Portfolio analysis and the product life cycle/ HC.Barksdale, C.E.Harris //Ong Range Planning, 1982, Vol.15, December, p. 74 -83.
5. Bian, D. Using the product life cycle as a marketing tool// Product management, 1974, Vol.3, October, p. 38 -42.
6. Burstein, M. Life-cycle costing. NAA conference proceedings, cost accounting for the 90's: Responding to technological change. P. 257 -271.
7. Day, G. The product life cycle: Analysis and application issues// Journal of Marketing, 1981, Vol. 45, p. 60 -67.
8. Dhalla, N.K. Forget the product life cycle concept/ N.K.Dhalla, S.Yuspeh// Harvard Business Review, 1976, Vol. 54, Jaunary-February, p.102 -113.
9. Dunnett, M. Evaluation of IBM end of life products: measuring DFE effectiveness/M.Dunnett, E.Grenchus,R.Keene, L.Yehle etc.// Proceedings of the 1999 IEEE International Symposium on Electronics & the Environment, Danvers, MA, 1999, 11-13 May, p. 98 - 103.
10. Emblemsvag, J. Activity-Based Cost and Environmental Management: A Different Approach to the ISO14000 Compliance/ J. Emblemsvag, B.Bras. Boston, MA: Kluwer Academic Publishers, 2000. 317 p.
11. Emblemsvag, J. LCA Comparability and the Waste Index/J. Emblemsvag, B.Bras// International Journal of Life Cycle Assessment 4(5), 1999, September, p. 282 -290.
12. Emblemsvag, J. Life Cycle Costing Using Activity-Based Costing and Monte Carlo Methods to manage Future Costs and Risks. Wiley John Wiley & Sons, inc. 2004.
13. Field, F.R. Life cycle analysis and its role in product and process development/F.R.Field, J.A.Isaacs, J.P.Clark// International Journal of Environmentally Conscious Design & Manufacturing, 1993, Vol.2, p.13-20.
14. Fuller, S.K. Life Cycle Costing Manual for Federal Energy Management Program / S.K.Fuller, S.R.Petersen. Washington, D.C.: Government Printing Office, 1996.
15. Gardner, D. The product life cycle: A critical look at the literature// Review of marketing, 1987, p. 162 -195.
16. Harvey, G. Life-cycle costing: a review of the technique//Management accounting, 1976, October, p. 343 -347.
17. Hawkins, P. Use Life-Cycle Costing to Justify Maintenance Projects// Maintenance management, 2002, p.1 -3.
18. Hoffmann, M. How can experiences from reuse activities influence the development of DEF - tools/ M.Hoffmann, R.Knoth, B.Kopacek, P.Kopacek// Proceedings of the 2001 IEEE International Symposium on Electronics & the Environment, Denver, CO, 2001, Vol.7-9 May, p. 264 - 267.
19. Lapašinskaitė, R. The Maintenance Cost Allocation in Product Life Cycle/ R.Lapašinskaitė, V.Boguslauskas// Engineering Economics, Kaunas: Technologija, 2005, p.17 -23.
20. Levitt, T. Exploit the Product Life Cycle //Harvard Business Review, 1965, November-December, p. 81 -94.
21. Ray, H. Garrison. Managerial Accounting (9thed.)/ H.Garrison Ray, W. Eric Norean. Irwin Mc Graw Hill, 2000.
22. Rink, D. Product life cycle research: A Literature review / D.Rink, J.Swan// Journal of business Research, 1979, Vol. 40, p. 219 -243.
23. Rose, C.M. A new approach to End-of-Life Design Advisor (ELDA)/C.M.Rose, A.Stevens, K.Ishii// Proceedings of the 2000 IEEE International Symposium on Electronics & the Environment, San Francisco, CA, 2000, Vol.8-10 May, p. 99-104.
24. Susman, G. Product life cycle management// Journal of cost man-

agement, 1989, Vol. 3, summer, p. 8 -22.

25. Wanyama, W. Life-cycle engineering: issues, tools and research// W.Wanyama, A.Ertas, H.C.Zhang, S.Ekwaro-Osire// International Journal of Computer Integrated Manufacturing, 2003, Vol.16, No 4-5, p.307 -316.
26. Wood, D. Evaluating the cost of alternative lighting system// Environmental design and Constructions, 2002, May-June.

Rūta Lapašinskaitė, Vytautas Boguslauskas

Išlaidų - laiko netiesiškumo ribinio taško tyrimas produkto gyvavimo cikle

Santrauka

Šiame straipsnyje aprašoma gyvavimo ciklo koncepcija, kuri gali būti panaudota siekiant įvertinti tikrus produkto kaštus. Tai gali padėti vadovams suprasti ir palyginti produkto įsigijimo kaštus su remonto kaštais. LCC metodas gali būti naudojamas renkantis alternatyvą: ar įsigyti naują produktą, ar remontuoti seną.

Gyvavimo ciklo koncepcijos nauda apibrėžiama taip:

- Gyvavimo ciklo koncepcija padeda padidinti generuojamas pajamas arba sumažinti kaštus daug labiau nei gali pasirodyti iš pirmo žvilgsnio;
- Geresni sprendimai turėtų gimi iš tikslesnio ir realesnio pajamų ir kaštų įvertinimo kiekvienoje produkto gyvavimo ciklo stadijoje;
- Mąstymas, paremtas gyvavimo ciklu, lemia ilgalaikį pelningumą;
- Gyvavimo ciklo koncepcija padeda vadovams suprasti ir palyginti įsigijimo kaštus su eksploataavimo ir remonto kaštais, t.y. surasti tikslų balansą tarp investavimo kaštų ir eksploataavimo kaštų.

Išskiriama keletas visuotinai sutartų teiginių (Gardner, 1987):

- Produktas turi ribotą gyvavimo laiką.
- Produkto pardavimai vyksta pagal S kreivę, matuojant metinį pardavimų lygį. Kritinis etapas yra tada, kai visiškai užimta rinka pradeda mažėti.
- Esminiai taškai pardavimų istorijoje matuojami etapais: įvedimas, augimas, branda ir produkto atsisakymas.
- Radus naujų vartojimo būdų ar naujų vartotojų, arba padidinus esamą vartotojų vartojimą, galima prailginti produkto gyvavimo ciklą.
- Vidutinis produkto vieneto pelningumas auga ir krinta, produktui judant per jo gyvavimo ciklo fazes.

Projektuojant eksploataavimo ir remonto kaštus per laikotarpį, labai svarbu įvertinti infliacijos įtaką žaliavų, darbo ir energijos kainų pasikeitimui per laikotarpį. Turint šią informaciją, galima suskaičiuoti visus įsigijimo, naudojimo ir remonto kaštus per produkto gyvavimo ciklą.

Vertinant produkto kaštus, labai svarbu prognozuoti veiklos išlaidas per produkto gyvavimo ciklą, nes, praėjus tam tikram laikotarpiui, eksploataavimo kaštai gali tapti dešimtis kartų didesni už įsigijimo kainą. Dėl šios priežasties labai svarbu nuolat vertinti veiklos kaštus, kad būtų galima laiku apsispręsti dėl produkto vartojimo tęstinumo.

Visi produkto kaštai gali būti įvertinti gyvavimo ciklo kaštų (LCC) metodu. Taikant šį metodą, apskaičiuojami visi kaštai, įskaitant įsigijimo kaštus, kapitalo kaštus, eksploataavimo ir remonto išlaidas, atsirandančias per produkto gyvavimo ciklą.

LCC metodu galima įvertinti, ar įsigyti naują produktą ar remontuoti esamą. Bet kuriuo atveju reikėtų pasirinkti tą variantą, kurio akumuliuoti kaštai būtų mažiausi.

Remontuoti ar pakeisti? Kai kalbama apie ilgalaikį turta, tai labai svarbus klausimas. Tai taip pat verslo sprendimas, paremtas kaštų ir generuojamų pardavimų apimties palyginimu. Prieš einant pas vadovybę su remonto ar naujo produkto įsigijimo rekomendacijomis, svarbu sugebėti paaiškinti, kaip bet kuris pasirinkimas paveiktų pasuktinę Pelno (nuostolių) ataskaitos eilutę.

Šio straipsnio tikslas – rasti lūžio tašką, kuriame eksploataavimo ir remonto kaštai tampa lygūs produkto įsigijimo kaštams.

Straipsnio objektas – įsigijimo, eksploataavimo ir remonto kaštai produkto gyvavimo cikle.

Gyvavimo ciklo kaštai apibrėžiami kaip suma tiesioginių, netiesioginių, atsitiktinių ir susijusių kaštų, patiriamų produkto kūrimo, vystymo, gamybos, remonto ir palaikymo fazėse, siekiant, kad pro-

duktas išlaikytų naudingąsias savybes.

Pirmasis žingsnis vertinant produkto gyvavimo ciklo kaštus – nustatyti visus kaštus, susijusius su visomis įmanomomis alternatyvomis. Šie kaštai turėtų būti identifikuoti kaip instaliaciniai kaštai (žaliavos ir darbas), energijos kaštai per metus, remonto ir eksploataavimo kaštai per metus. Antrajame žingsnyje reikia prognozuoti eksploataavimo ir remonto kaštus per metus. Trečiajame žingsnyje apskaičiuojama esamoji vertė būsimųjų eksploataavimo ir remonto kaštų. Įvertinant kapitalo kaštų įtaką, ateities eksploataavimo ir remonto kaštai perskaičiuojami į esamąją vertę.

Vartotojas turi mažiausiai tris galimybes: galima daryti labai didelės investicijas remontuojant produktą, galima įsigyti naują produktą arba tiesiog nedaryti nieko. Kiekviena galimybė atspindi investavimo alternatyvas, ir kiekviena galimybė gali būti apibrėžta ir pritaikyta siekiant parodyti kaštų poveikį priimamam sprendimui. Rezultatų analizė galės padėti atsakyti į klausimą, kurį investavimo būdą, turintį daugiausiai privalumų, pasirinkti.

Pirmoji alternatyva yra nedaryti nieko. Paprastai tai mažiausiai patrauklus pasirinkimas eksploataavimo ir remonto skyriui.

Antroji alternatyva – pirkti naują produktą. Šiuo atveju reikėtų rinktis iš keleto galimybių. Tarp „nieko nedarymo“ ir „pirkimo naujo“ gali būti kita verta dėmesio galimybė, turint minimalistinį požiūrį į remontą, kas apibrėžta kaip „optimali“ remonto strategija. Tai trečioji investavimo alternatyva. Kai kurie požiūriai gali pailginti įrengimo gyvavimo ciklą, kai kurie – netgi jį sutrumpinti.

Suskaičiuojant kiekvieno scenarijaus kaštus, lieka vienas kritinis žingsnis: atlikti visų scenarijų finansinę analizę. Analizėje turėtų atsišpindėti diskontavimo veiksniai, infliacijos įtaka išlaidoms, balanso pasikeitimas, finansiniai kaštai, nusidėvėjimas ir netgi kiti investavimo pasirinkimai, galintys veikti išlaidas, net jei įmonei šiuo metu tai nenumatyta.

Smulkiai ištyrus visus veiksnius, nesunku pasirinkti teisingą investavimo strategiją – remontuoti seną įrengimą, įsigyti naują ar nedaryti nieko.

Remonto kaštai produkto gyvavimo cikle dominuoja, nes remontas paprastai atliekamas per visą produkto eksploataavimo laikotarpį.

Naudojant eksponentinės regresijos metodą, buvo apskaičiuotas išlaidų -laiko lūžio taškas, kuriame akumuliuotos eksploataavimo ir remonto išlaidos pasiekia lygį, kai labiau verta įsigyti naują produktą, turint tuos pačius išteklius, nei naudoti senąjį. Išlaidų -laiko netiesiškumo ribinis taškas parodo laikotarpį, kuriuo akumuliuoti eksploataavimo kaštai yra lygūs produkto įsigijimo kaštams.

Lūžio taškas buvo rastas kompiuterine programa VisSim 5.0.

Remiantis iškelta prielaida, buvo teigiama, kad, norint eksploatuoti turimą produktą, kiekvienais metais teks patirti vis daugiau ir daugiau remonto ir eksploataavimo kaštų. Kaštai auga pagal didėjančią normą:

$$y = ce^{dx}$$

Laikas po produkto įsigijimo yra pridedamas kaip modelio generatorius, kuris padeda analizuoti kaštus skirtingais laikotarpiais matematiname modelyje. Šis modelis skaičiuoja akumuliuotas eksploataavimo ir remonto kaštus kiekviename laiko periode ir lygina su įsigijimo verte.

Atlikus visus modelio skaičiavimus, galutinis sprendimas yra paprastas: pasirinkti mažiausiai kaštų reikalaujantį investavimo variantą. Mažiausių kaštų požiūris gali padėti įvertinti labai platų projektų ir finansinių mechanizmų spektrą. Visais atvejais produkto gyvavimo ciklo kaštų skaičiavimas padės atlikti labai tikslų įvertinimą finansinių rodiklių.

Išvados:

1. Yra išskiriamos trys pagrindinės produkto gyvavimo ciklo pabaigos strategijos: remontuoti produktą, įsigyti naują produktą arba nedaryti nieko.
2. Eksploataavimo ir remonto kaštai yra dominuojantys kaštai produkto gyvavimo cikle, nes jie patiriami visą produkto eksploataavimo laikotarpį.
3. Laiko-kaštų lūžio taškas rodo produkto gyvavimo ciklo periodą, kuriame akumuliuotos remonto ir eksploataavimo išlaidos tampa lygios naujo produkto įsigijimo išlaidoms.

Raktažodžiai: *gyvavimo ciklo apskaita, produkto gyvavimo ciklas, laiko – išlaidų lūžio taškas.*

The article has been reviewed.

Received in December, 2005; accepted in February, 2006.

DOI: 10.5755/j01.ee.46.1.11358